



**Model: 116155-00**

**DESCRIPTION**

- Two stage
- 24 volts
- 5.7"/145 mm diameter
- Double ball bearings
- Single speed
- Peripheral bypass discharge
- Thermoset fan end bracket
- Aluminum commutator bracket

**DESIGN APPLICATION**

- Equipment operating in environments requiring separation of working air from motor ventilating air
- Designed to handle clean, dry, filtered air only

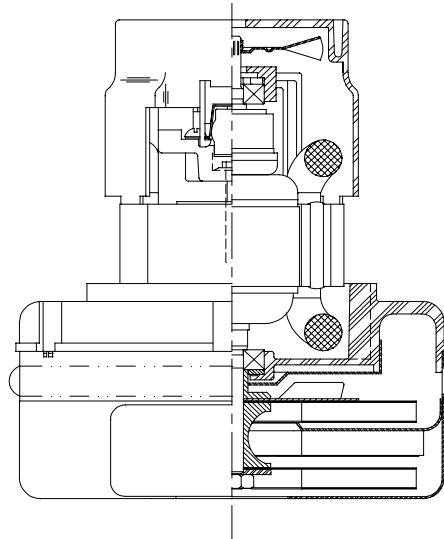

**SPECIAL FEATURES**

- Suitable for 24 volt D.C. operation
- UL recognized, category PRGY2 (E47185)
- Provision for grounding
- Epoxy painted fan case
- Patented air seal bearing construction. U.S. Patent #4,088,424
- The Lamb Electric vacuum motor line offers a wide range of performance levels to meet design needs

**TYPICAL MOTOR PERFORMANCE.\***

(At 24 volts, 60Hz, test data is corrected to standard conditions of 29.92 Hg, 68° F.)

**ASTM DATA**

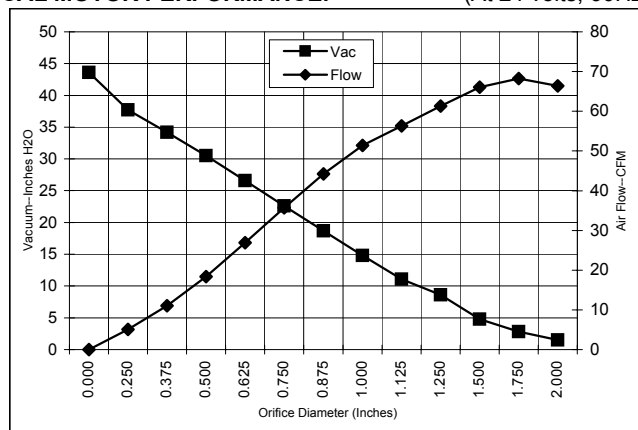

Orifice (Inches)	Amps	Watts (In)	RPM	Vac (In.H <sub>2</sub> O)	Flow (CFM)	Air Watts
2.000	14.0	344	12600	1.5	66.4	12
1.750	14.0	344	12550	2.8	68.2	22
1.500	14.2	348	12500	4.8	66.1	38
1.250	14.4	353	12400	8.6	61.3	62
1.125	14.4	353	12400	11.1	56.3	74
1.000	14.3	351	12400	14.8	51.4	89
0.875	14.1	346	12500	18.7	44.2	98
0.750	13.6	334	12750	22.6	35.7	95
0.625	13.2	324	13100	26.6	26.9	84
0.500	12.5	307	13700	30.5	18.4	66
0.375	11.8	292	14250	34.2	11.0	44
0.250	11.3	277	14800	37.7	5.1	23
0.000	10.8	265	15500	43.6	0.0	0

**METRIC DATA**

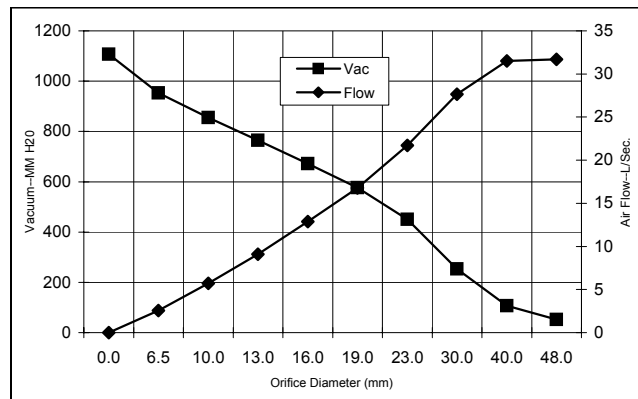

Orifice (mm)	Amps	Watts (In)	RPM	Vac (mm H <sub>2</sub> O)	Flow (L/Sec)	Air Watts
48.0	14.0	344	12578	53	31.7	16
40.0	14.1	347	12515	107	31.5	33
30.0	14.4	353	12400	253	27.6	69
23.0	14.2	347	12475	450	21.7	96
19.0	13.6	334	12757	576	16.8	95
16.0	13.2	324	13086	672	12.9	84
13.0	12.6	309	13640	765	9.1	68
10.0	11.9	294	14168	855	5.7	47
6.5	11.3	278	14773	953	2.5	24
0.0	10.8	265	15500	1107	0.0	0

Note: Metric performance data is calculated from the ASTM data above.

\* Data represents performance of a typical motor sampled from a large production quantity. Individual motor data may vary due to normal manufacturing variations.

<b>Test Specs:</b>	<b>24 volts</b>	<b>Minimum Sealed Vacuum:</b>	<b>41.4"</b>	<b>ORIFICE:</b>	<b>7/8"</b>	<b>Minimum Vacuum:</b>	<b>17.5"</b>	<b>Maximum Watts:</b>	<b>431</b>
--------------------	-----------------	-------------------------------	--------------	-----------------	-------------	------------------------	--------------	-----------------------	------------

**DIMENSIONS**

NOTES:

1. LEADS: 14 GA STRANDED, LEADS CAN BE ANY COLOR EXCEPT GREEN OR GREEN WITH YELLOW STRIPE.
2. GROUNDING OR EARTHING PROVISIONS: USE HOLES AS INDICATED FOR GROUNDING OR EARTHING. REFER TO APPROPRIATE LISTING OR REGULATORY AGENCY FOR PROPER METHOD OF GROUNDING OR EARTHING.
3. RECOMMENDED SCREW SIZE 10-16 TYPE BT OR TYPE 25 THREAD CUTTING SCREW. MAXIMUM PENETRATION 17.40/.685.

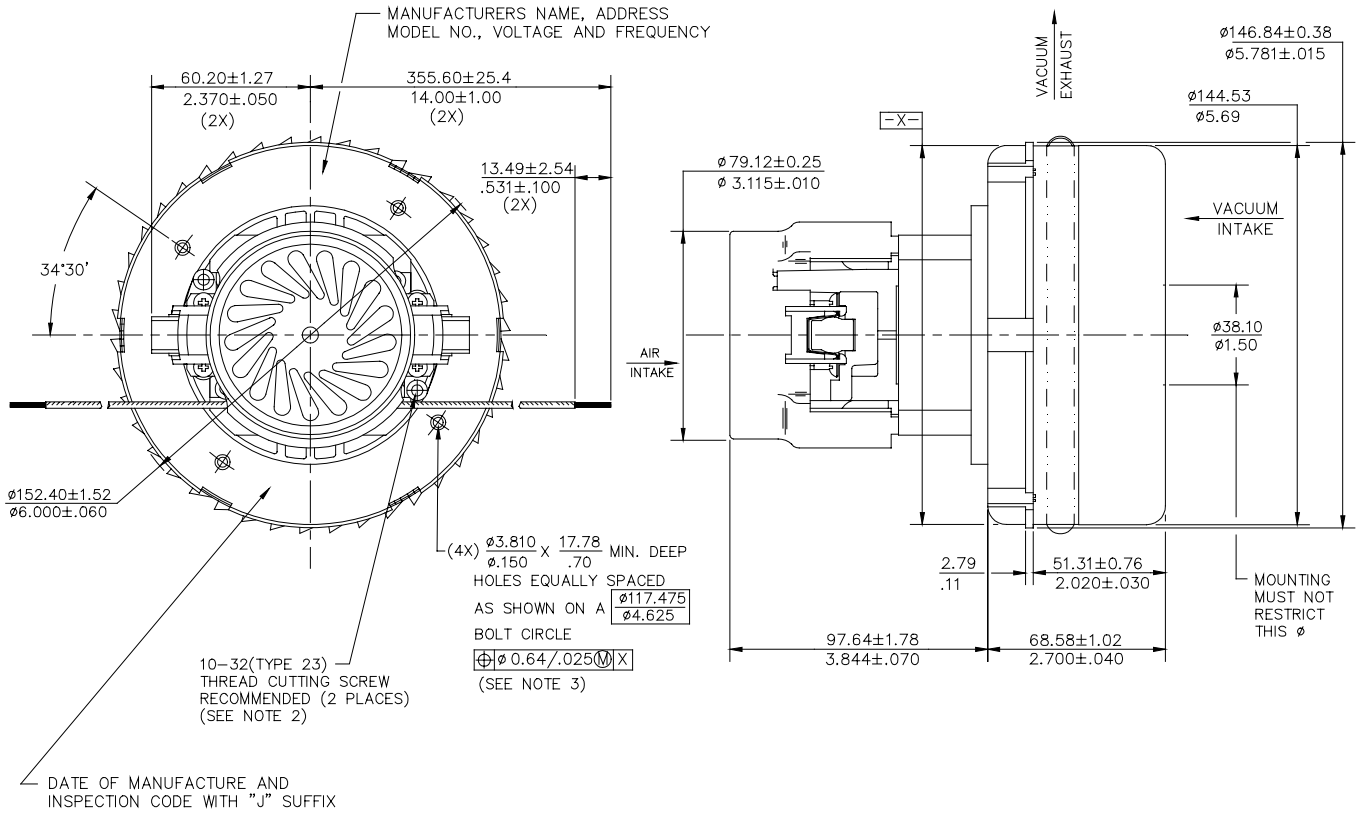

**IMPORTANT NOTE:** Pictorial and dimensional data are subject to change without notice. Contact factory for current revision levels.

**WARNING** - When using AMETEK Lamb Electric bypass motors in machines that come in contact with foam, liquid (including water), or other foreign substances, the machine must be designed and constructed to prevent those substances from reaching the fan system, motor housing, and electrical components. Lamb Electric vacuum motors other than hazardous duty models should not be applied in machines that come in contact with dry chemicals or other volatile materials. Failure to observe these precautions could cause flashing (depending on volatility) or electrical shock which could result in property damage and severe bodily injury, including death in extreme cases. All applications incorporating Lamb Electric motors should be submitted to appropriate organizations or agencies for testing specifically related to the safety of your equipment.

**AMETEK/Lamb Electric Division**  
627 Lake Street  
Kent, Ohio 44240  
U.S.A.  
Tel: (330) 673-3451  
Fax: (330) 673-8994

**Ametek GmbH**  
P. O. Box 1251  
D-71667 Marbach  
Germany  
Phone: + 49-714-484-9512  
Fax: + 49-714-484-9513

**AMETEK/Singapore Private Limited**  
10 Ang Mo Kio Street 65  
# 05-12 Techpoint  
Singapore 2056  
Tel: + 65-484-2388  
Fax: + 65-481-6588