

Technical  
Drawing

Desenho  
Técnico

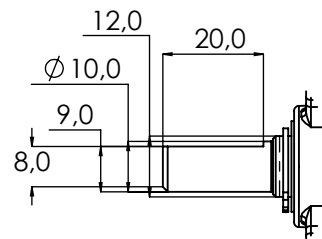

DETALHE N  
ESCALA 2 : 3

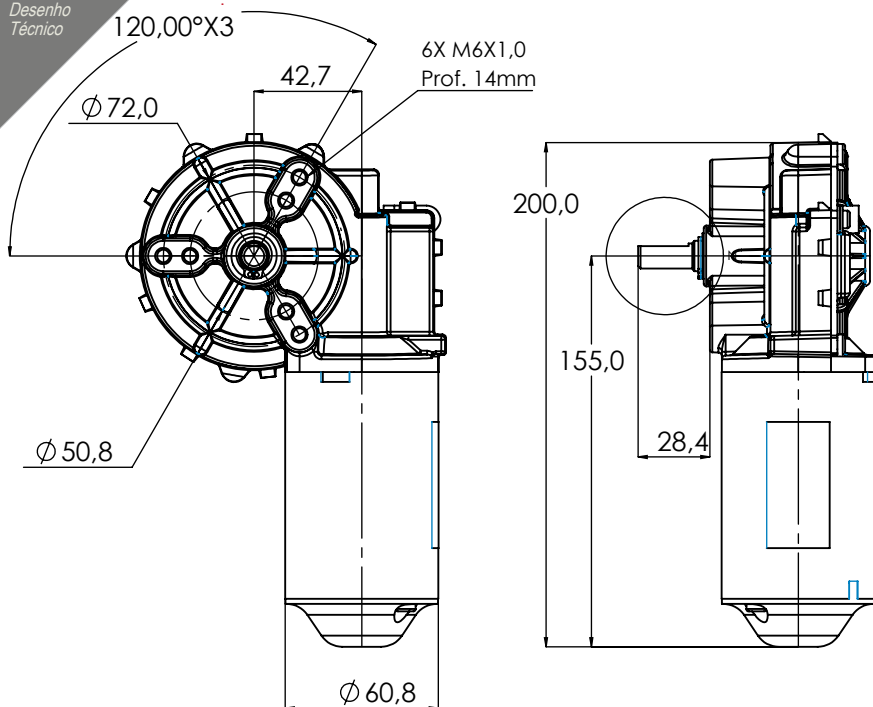
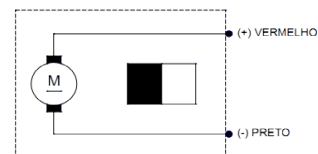
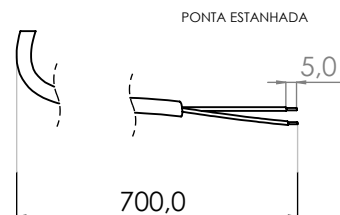

Technical  
Specification

Especificação  
Técnica

Imagem  
Ilustrativa

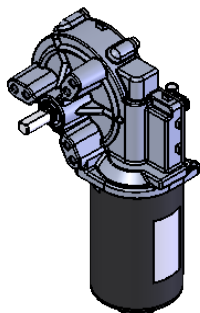

100502812

CARACTERÍSTICAS ELÉTRICAS	
U N (V)	13
P N (W)	21
n N (rpm)	30
I N (A)	3,5
I max (A)	17
M N (Nm)	6
M max (Nm)	39
I	55:1
Rotação	L / R
Peso (Kg)	1,500

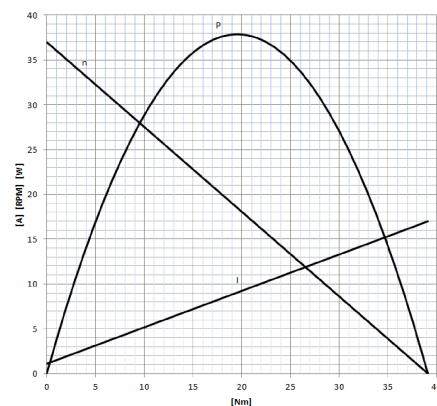

100502824

CARACTERÍSTICAS ELÉTRICAS	
U N (V)	27
P N (W)	20
n N (rpm)	30
I N (A)	2,5
I max (A)	10,5
M N (Nm)	6
M max (Nm)	37
I	55:1
Rotação	L / R
Peso (Kg)	1,500

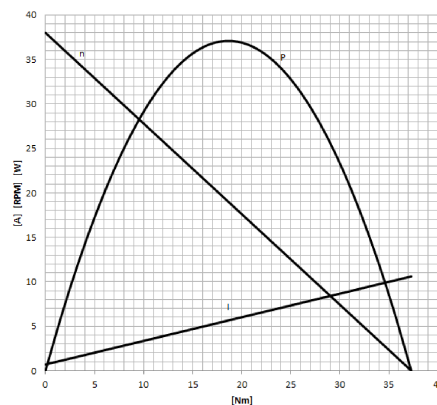

NOTAS:

Aplicação: Industrial

NOTES:

Application: Industrial